

SPEARHEAD

MULTICUT 200



The Multicut 200 is the toughest 2.0 metre rotary mower of its kind.

Designed and manufactured without any compromise on quality to provide a heavy duty and robust vegetation maintenance machine.

Featuring the unique high lift HD3 blade arrangement with three 12 millimetre thick blades or alternatively the heavy duty swipe chain kit — this specialist model is suitable for cutting and mulching scrub and vegetation of up to 100 millimetre in diameter.

With full length skids, floating linkage and rear gauge wheel the Multicut 200 provides a consistent cut on even the most undulating terrain.

TRACTOR HP	PTO SPEED	TRANSPORT WIDTH	CUTTING WIDTH	GEARBOX RATING	NUMBER OF WHEELS	NUMBER OF ROTORS	NUMBER OF BLADES	CUTTING HEIGHT
45hp	540rpm	2.08m / 6' 10"	2.00m / 6' 6"	110hp	1	1	3	50 - 250mm 2" - 8"

MULTICUT 200

UNIT OPTIONS



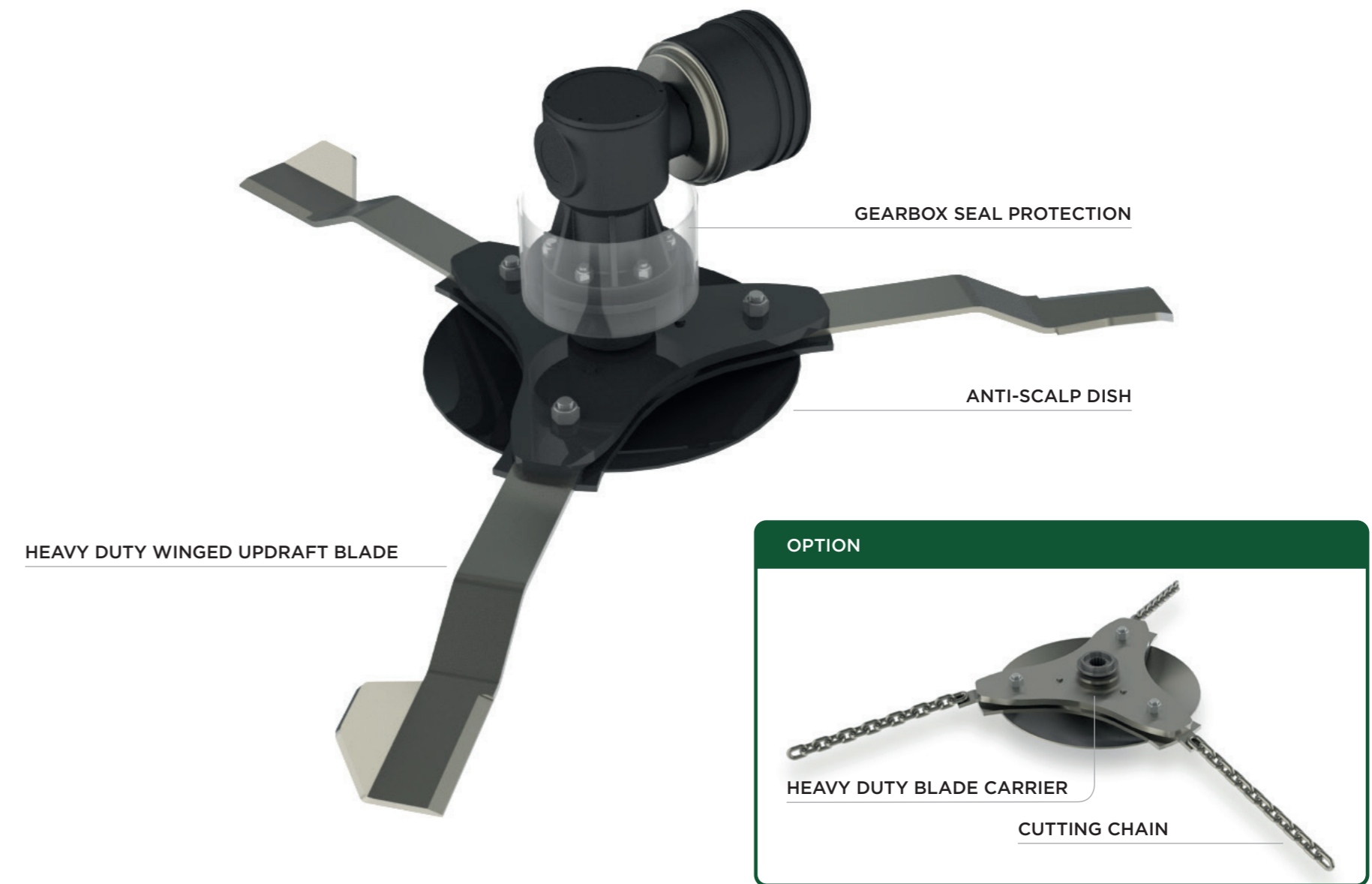
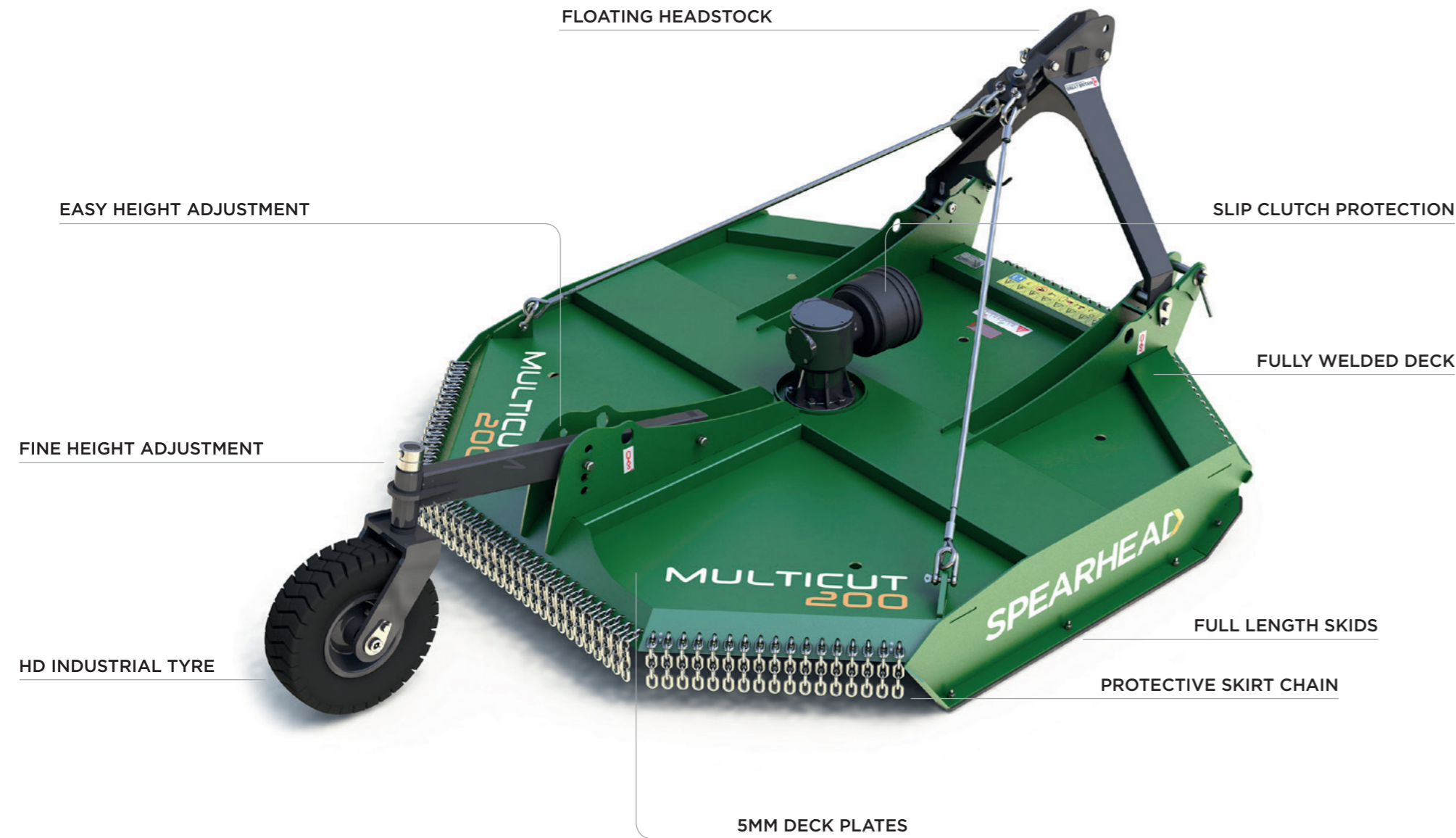

MACHINE	MULTICUT 200		
Machine weight*	610kg / 1344lbs	Deck material thickness	5mm (3/16")
Hitch	Category 2 with floating clevis top link	Side skirt material thickness	6mm (1/4")
Cutting width	2.00m / 6' 6"	Skid construction	Replaceable bolt on skid shoes
Overall width	2.08m / 6' 10"	Anti-scalp dish	6mm (1/4") round pan with blade holder bar
Overall length	3.02m / 9' 11"	Blades (x3)	12mm (1/2") 30 Carbon Boron hardened and tempered. Free swinging high lift - low friction
Deck height**	0.24m / 10"	Blade bolts	M24 C/W shank grade 8.8
Cutting height	50mm - 250mm (2" - 8")	Blade tip speed	85mps / 16732fpm
Cutting capacity	100mm / 4"	Driveline	ASAE Category 4
Recommended tractor HP	45hp / 34kW	Driveline protection	2 plate slip clutch
Power take-off speed	540rpm	Tailwheel mount assembly	Welded box section arm and caster fork with 360 degree swivel
Gearbox	Cast Iron housing	Tailwheel	5.00-8 rubber tyre with steel hub
Input shaft	1-3/8" Z6 input shaft	Front guard	Single chain guard
Gearbox lubricant	EP80-90W or GL-4 / GL-5 oil	Rear guard	Single chain guard
Gearbox oil capacity	2.1 litres / 3.7 pints		
Deck construction	All welded construction		

* With front and rear single chain guards ** Underside of deck to skid

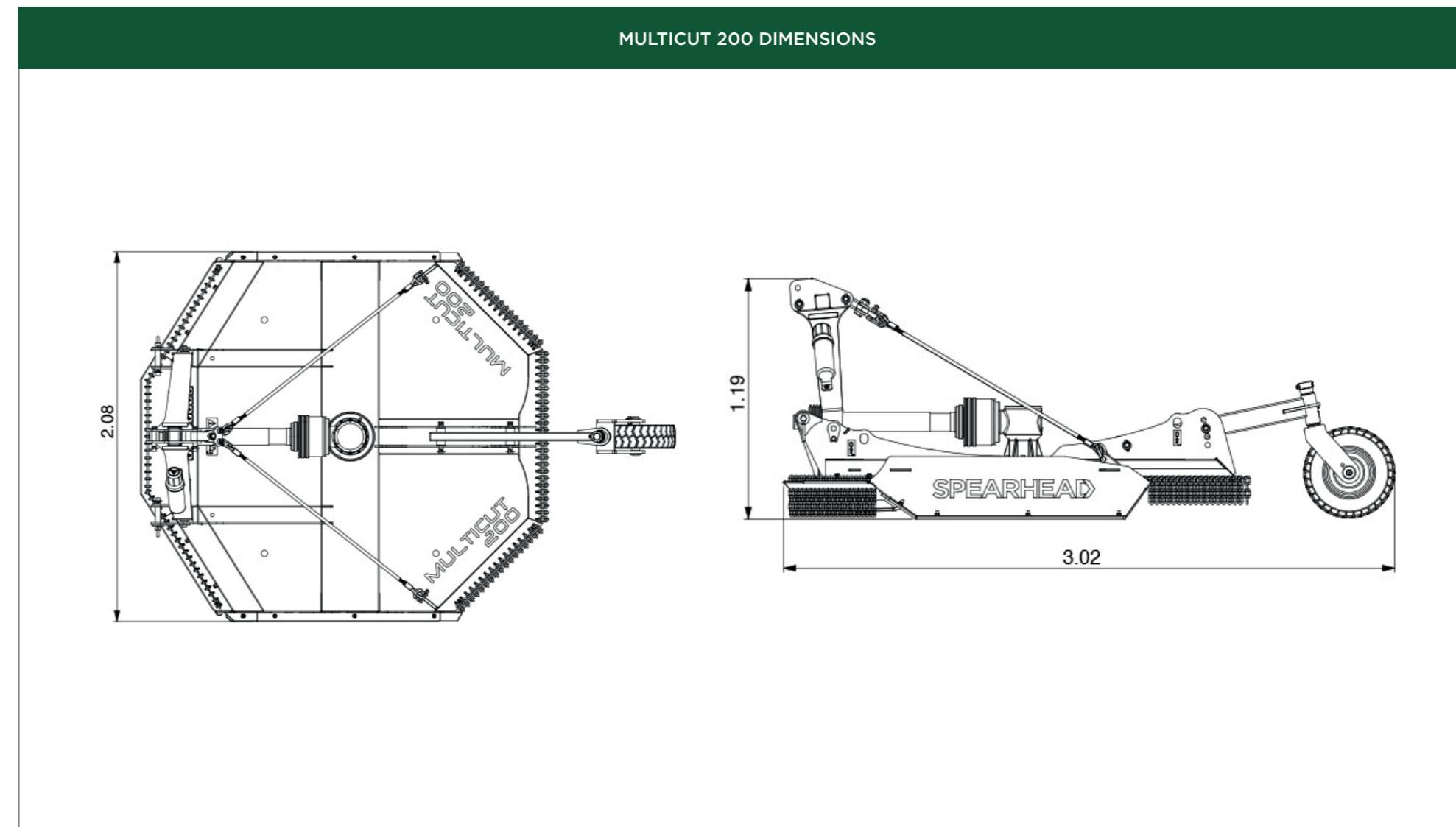

SPEARHEAD

📍 Station Road, Salford Priors, Evesham, Worcestershire, WR11 8SW, England

☎ +44 (0)1789 491860

✉ enquiries@spearheadmachinery.com

🌐 spearheadmachinery.com

🐦 📘 Spearhead World



designed and built in
GREAT BRITAIN 

Spearhead
is a member of the

Alamo Group